

# CEILING SYSTEMS

CI/SfB | (35) | Xy |  
September 2009

Between us, ideas become reality®

## Armstrong® TECH ZONE

Innovative solutions, integrating service elements  
to create more flexible, homogeneous ceilings.

[www.armstrong-ceilings.co.uk/techzone](http://www.armstrong-ceilings.co.uk/techzone)  
[www.armstrong-ceilings.ie](http://www.armstrong-ceilings.ie)

**Armstrong®**



# Armstrong® TECH ZONE

## CONCEPT

With the introduction of TECH ZONE, Armstrong has raised the bar, inspiring & influencing architectural trends! Developed by Armstrong, TECH ZONE is a **partnership with industry leaders** in lighting fixtures, loudspeakers, air diffusers, chilled beams and sprinkler systems.

Armstrong® TECH ZONE offers you a unique solution to design contemporary, technical zones with the guaranteed integration of market leading service elements.

TECH ZONE provides customised ceiling solutions using standard ceiling and technical elements:

- Create a customised, homogeneous ceiling to design, organise and integrate different service elements.
- Minimal grid visibility provides a clean and sophisticated ceiling finish.
- A large variety of ceiling tile materials and modules are available to meet the design and acoustic demands of any space.
- TECH ZONE design flexibility allows the possibility to integrate continuous technical fixtures, for a clean visual.
- TECH ZONE can also be integrated into an Axiom Canopy, offering design solutions for Thermal Mass.
- Flexibility to re-configure room layouts and service element positions without moving ceiling panels.

TECH ZONE guarantees the compatibility and integration of the following technical elements:

- Light fixtures for multiple applications: individual integrated luminaires, continuous linear fittings and pendant lights.
- Air conditioning for traditional and innovative solutions: air diffusers and chilled beams.
- Flexible sprinklers for easy adaptation to any ceiling lay-out and fast installation, saving time and labour.
- Active sound panels for diffusion of music, public address, voice alarm or sound masking.

With TECH ZONE, edge detailing & colour matching is guaranteed. All technical elements supplied via this unique partnership are fully compatible with Armstrong tile and grid systems.

Our TECH ZONE Partners:



PHILIPS



ZUMTOBEL

# Armstrong® TECH ZONE

## DESIGN OPTIONS

Armstrong® TECH ZONE is easy to specify and install.

Although building modules can vary country to country, Armstrong can provide a solution to meet your individual needs.

Armstrong® TECH ZONE is compatible with the more popular building modules (1200mm, 1350mm, 1500mm, 1800mm, ...). The technical zone can be installed parallel or perpendicular to the façade.

The combinations of suspension systems, tiles and technical elements are almost unlimited.

The following illustrations give you a flavour of what you can achieve.

A more detailed 'Technical Guide' is also available. You can find details on all the suggested lay-outs including technical details on grid, tile and technical components.

To specify and design a system, you just have to follow the following steps:

- 1 Select the ceiling module.
- 2 Determine the on-centre spacing of the linear technical zone.
- 3 Choose the dimensions and edge details of the Field Panels.
- 4 Select the grid that's compatible with Armstrong® TECH ZONE.
- 5 Select the edge detail and material of the Technical Panel.
- 6 Choose the Technical Elements to be integrated.



Building module 1200x1350.  
1200x1200 mm Optima MicroLook tiles on Interlude grid.

### Open space

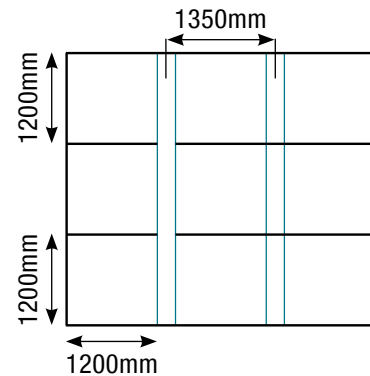

- Large tile modules provide a trendy, modern visual to any open space.
- A narrow suspension system contributes to the homogeneous finish.
- High sound absorbing ceiling materials enhance and improve concentration and privacy conditions, and can be further enhanced by use of active acoustics to provide sound masking.

Armstrong recommends Optima, Ultima OP, Perla OP tiles on Interlude grid.



## Partitioned offices and meeting rooms with adjacent open spaces

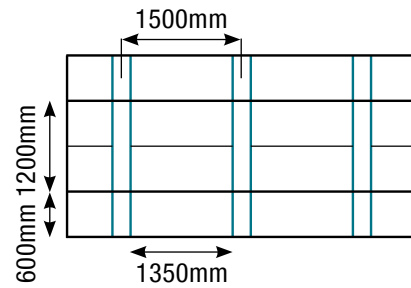

- The TECH ZONE system provides visual continuity between different types of spaces.
- Grid alignment with the ceiling tiles surface for integration of demountable partitions.
- A balance between sound absorption and sound attenuation will improve end user comfort and increase confidentiality.

Armstrong recommends Ultima, Orcal Extra Micro-perforated with B15, on Interlude or Silhouette grid.

Building module 1200x1500.  
1350x600 mm Ultima MicroLook Field Panels and 1200x150 mm Ultima MicroLook Technical Panels on Silhouette grid.



## Conference Room

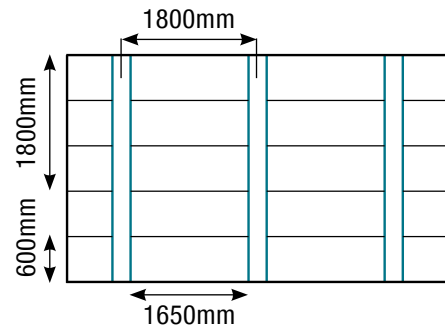

- Rectangular tiles to provide more depth to small spaces.
- Sound absorbing ceiling materials will provide improved speech intelligibility.

Armstrong recommends Ultima, Sierra tiles on Interlude or Silhouette grid.

Building module 1800x1800.  
1650x600 mm Sierra Board Field Panels and 1800x150mm Sierra Board Technical Panels on Prelude 24 grid.



## Call centre

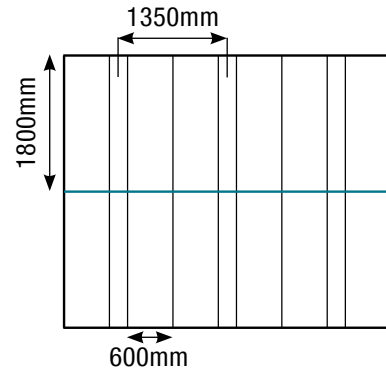

- Larger panel sizes provide an enhanced perception of space.
- High sound absorbing materials are ideal for improving concentration and privacy in open plan spaces.

Armstrong recommends Perla OP, Ultima OP or Sierra.

Building module 1350x1800.  
1800x600 mm Ultima OP MicroLook Field Panels and 1800x150 mm Sierra Board Technical Panels on Interlude grid.



## Reception hall

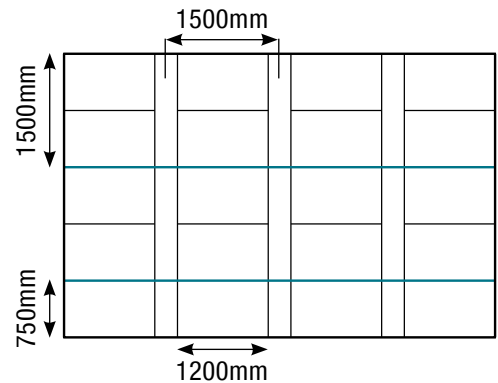

- Reception areas often feature hard materials such as stone and glass. High absorbing ceiling materials are therefore more critical for reducing reverberation in these spaces.

Armstrong recommends Optima or Orcal Extra Microperforated with B15.

Building module 1500x1500.  
1200x750 mm Optima Tegular Field Panels and 1500x300 mm Optima Tegular Technical Panels on Prelude 24 grid.



Building module 1200x1350.  
1200x1200 mm Optima MicroLook tiles and Interlude grid  
in an Axiom Canopy.

## Shops

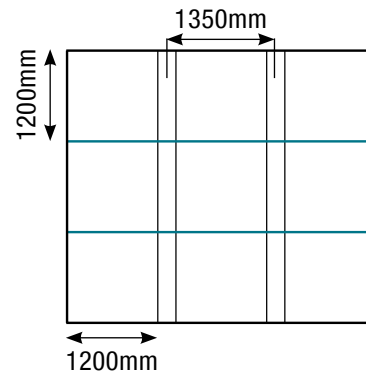

- Ease of directional lighting integration, installation & relocation of services compared to plasterboard ceilings.
- TECH ZONE suspension systems with Axiom canopies allow the creation of clouds for modern design.
- Invisible speakers for music and marketing messages integrate into TECH ZONE with no detriment to the overall appearance.

Armstrong recommends Optima, Ultima OP, Perla OP, Orcal Extra Microperforated and Sierra tiles on Interlude or Prelude 15 mm grid.



Building module 1200x1500.  
1200x1200 mm and 1200x150 mm Orcal Extra Microperforated tiles  
on Interlude grid.

## Showroom

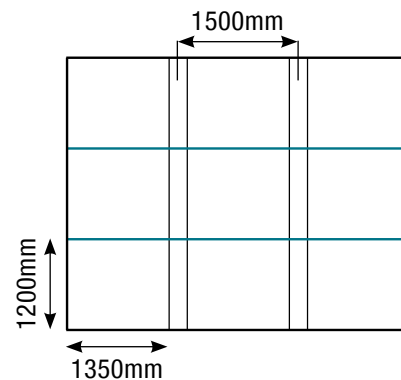

- Large metal tiles provide a deluxe, modern finish.
- Guaranteed colour match of the suspension systems, metal tiles and Technical Elements.
- Although the Extra Microperforation is virtually imperceptible, it still provides good sound absorption to control excessive reverberation.

Armstrong recommends Orcal Extra Microperforated tiles on Interlude grid.

# Armstrong® TECH ZONE

## INSTALLATION

TECH ZONE combines:

- Suspension Systems,
- Field Panels (FP, installed between technical zones),
- Technical Panels (TP, installed in technical zones),
- Technical Elements (TE: Luminaires, air diffusers, sound panels... installed in technical zones).

Our Omega Contractors have the necessary installation & technical experience to install your TECH ZONE project successfully.

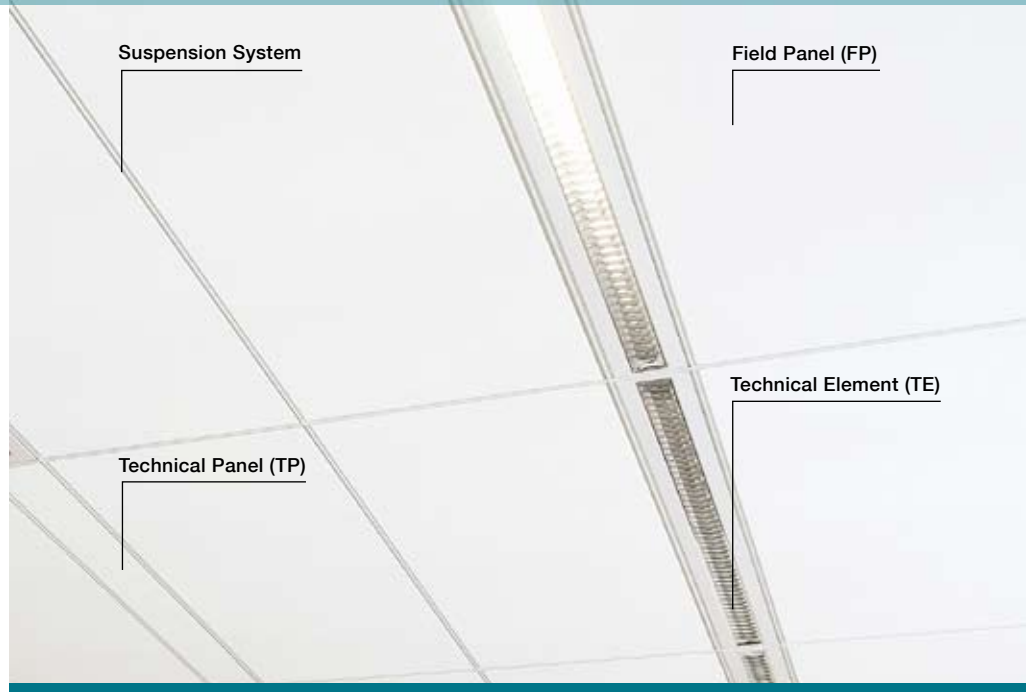

### How to install Armstrong® TECH ZONE ceiling system in 3 steps:

1

Simple and fast assembly of Armstrong® TECH ZONE suspension systems to create 150 or 300mm wide technical zones, for luminaires, air diffusers, sprinklers, chilled beams and loudspeakers.

2

Perfect integration of made-to-measure Technical Elements.

3

Installation of made-to-measure ceiling tiles, including 150 or 300mm wide Technical Panels.

#### Option 1: Main Runners perpendicular to the technical zone

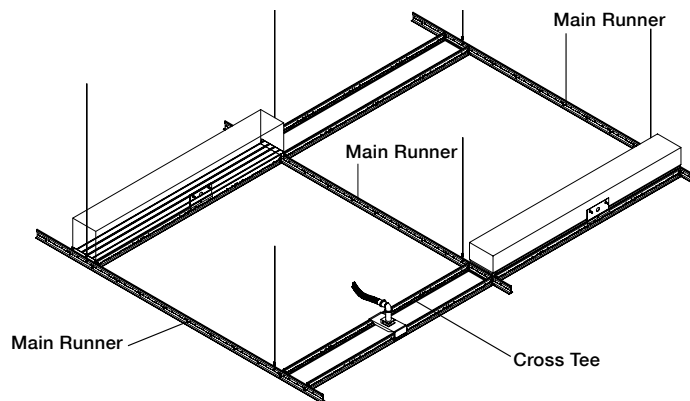

#### Option 2: Main Runners parallel to the technical zone

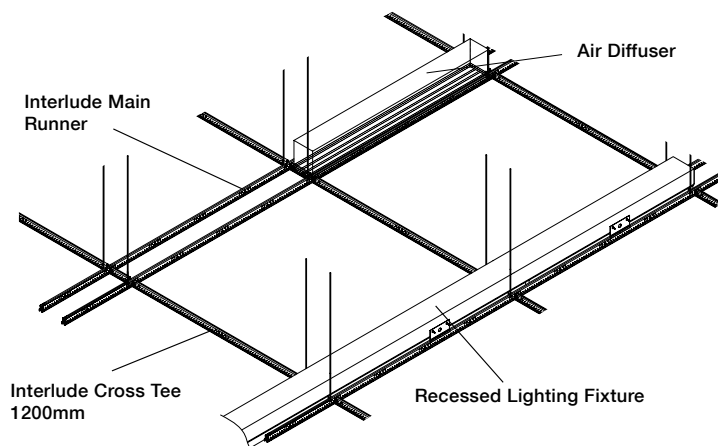

In case you want to integrate continuous luminaires or Technical Elements of different lengths, the Main Runners need to be installed parallel to the technical zone and small Cross Tees need to be added wherever necessary.



# FIELD AND TECHNICAL PANELS & EDGE DETAILS

## Matching edge details of the Field Panel, Technical Panel or Technical Element.

Technical Panels width:  
150 or 300mm.  
Technical Panels lengths:  
1200, 1350, 1500 and 1800mm.

Section Drawing	Suspension Systems	Field Panel Edge Details	Technical Panel or Technical Elements Edge Details
	Prelude 24	Board	Board
	Prelude 24	Tegular 8 mm	Tegular 8 mm
	Prelude 24	SL2/Tegular TZ 8 mm	Tegular 8 mm
	Prelude 24	Vector 14 mm	Tegular 14 mm
	Prelude 15	MicroLook 8 mm	MicroLook 8 mm
	Interlude 15	MicroLook 8 mm	MicroLook 8 mm
	Silhouette 15	MicroLook 8 mm	MicroLook 8 mm

Examples of edge detail options are shown below.



SL2/Tegular TZ Field Panel and Tegular Technical Panel on Prelude 24.



Vector Field Panel and Tegular Technical Panel on Prelude 24.



Tegular Field Panel and Tegular Technical Panel on Prelude 24.



MicroLook Field Panel and MicroLook Technical Panel on Prelude 15.



Board Field Panel and Board Technical Panel on Prelude 24.



MicroLook Field Panel and MicroLook Technical Panel on Interlude 15.



MicroLook Field Panel and MicroLook Technical Panel on Silhouette & Prelude 15.

NB: Silhouette Main Runners are always installed parallel to the technical zone, and are combined with Prelude 15 Cross Tees.

# Armstrong® TECH ZONE

## CASE STUDIES



**JOB SITE:** The Greenway Group  
**LOCATION:** Atlanta, USA  
**ARCHITECT:** DAG Architects, Destin  
**PRODUCT:** TECH ZONE Ceiling System

### **The Challenge:**

Create an office space that provides a functional working environment while incorporating elements that are contemporary and on the cutting edge of design innovation.

According to Jim Cramer, Greenway's Chief Executive, "When clients are in our office, we want them to leave with design ideas as well as strategic ideas."

**Clean & custom look, using standard components.**

### **The Solution:**

Armstrong® TECH ZONE Ceiling System creates a customised yet functional ceiling by providing the required quantity and quality of light and air into the space.

Cut outs are not needed in the acoustic Field Panels, making them aesthetically pleasing and easier to install and maintain.



**JOBSITE:** Clemmons Architecture  
**LOCATION:** St. Petersburg, USA  
**ARCHITECT:** Clemmons Architecture  
**PRODUCT:** TECH ZONE Ceiling System

### **The Challenge:**

Clemmons Architecture is renowned for its renovations of older structures.

They wanted to design a luxurious environment providing excellent acoustical comfort to a building with open plan offices, that dated back to 1926.

### **Renovation of a traditional ceiling system for acoustics & aesthetics.**

### **The Solution : TECH ZONE**

#### **Acoustics:**

“Our old offices had a lot of hard surfaces, including a plasterboard ceiling so there was not much auditory privacy. “The new ceiling makes a big difference, both in terms of privacy and the overall noise level.”

#### **Aesthetics:**

“We really liked the clean, modern look of the system,” he states. “Compared to a traditional ceiling system, it is far less busy. And, because of the size of the panels and their fine-textured surface, most visitors don’t even realise it’s an acoustical ceiling.”



### **Modular system for an easy installation.**

“We also liked the modularity of the system,” he adds, “because it eliminates much of the guesswork for the ceiling contractor in terms of where to place the lights, sprinklers and such. It’s much more predictable, which means fewer problems for the contractor.”

# Armstrong® TECH ZONE

## FIELD PANELS

	Edge Detail	Tiles Performances					Grid				
		Absorption	Attenuation	Light Reflectance	Humidity Resistance	Recycled Content*	Prelude 24	Prelude 15	Interlude	Silhouette	
<b>Optima<sup>(1)</sup></b>	Board, Tegular, MicroLook	0,95	N/A	≅ 85%	95%	82%	•	•	•	•	
	Vector	1,00	N/A	≅ 85%	95%		•	•	•	•	
<b>Ultima OP</b>	Board, Tegular, MicroLook	1,00	26	≅ 90%	95%	16%	•	•	•	•	
<b>Ultima</b>	Board, Tegular, MicroLook	0,70(H)	36	≅ 90%	95%	up to 71%	•	•	•	•	
	Vector	0,70(H)	37	≅ 90%	95%		•	•	•	•	
	SL2/Tegular TZ	0,70(H)	40	≅ 90%	95%		•	•	•	•	
<b>Perla OP</b>	Board, Tegular, MicroLook	0,95	25	≅ 90%	95%	16%	•	•	•	•	
<b>Sierra</b>	Tegular, MicroLook	0,85(H)	28	≅ 85%	95%	10%	•	•	•	•	
<b>Nevada<sup>(2)</sup></b>	Board, Tegular, MicroLook	0,90 - 1,00	24 - 27	≅ 85%	95%	25%	•	•	•	•	
<b>METAL</b>	<b>Orcal Extra Microperforated</b>	Board, Tegular, MicroLook	0,55(L) <sup>(3)</sup> - 0,65 <sup>(4)</sup>	30 <sup>(3)</sup> - 40 <sup>(4)</sup>	≅ 76%	95%	up to 25%	•	•	•	•

\* Calculated according to ISO 14021.

Fire Test for all tiles : Euroclass A2-s1, d0

(1) Optima Board, Tegular, MicroLook: 20mm

(2) Nevada: 18mm

(3) With Acoustic Fleece

(4) With Premium B15

### Edge detail

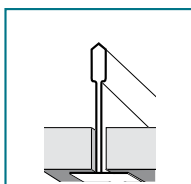

Board

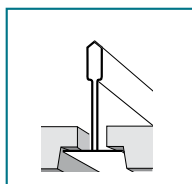

Tegular

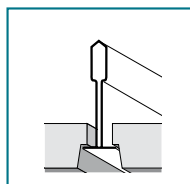

MicroLook

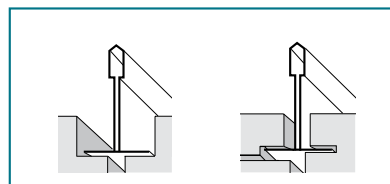

Vector

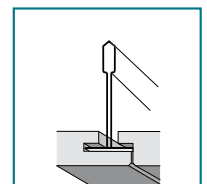

SL2/Tegular TZ

#### United Kingdom / Republic of Ireland

Armstrong World Industries Ltd.  
Building Products Division  
Armstrong House, 38 Market Square,  
Uxbridge UB8 1NG

0800 371849 (UK)

1800 409002 (ROI)

Fax: 00 44 (0) 1895 274287

sales-support@armstrong.com

www.armstrong-ceilings.co.uk/techzone

www.armstrong-ceilings.ie

#### Dubai | United Arab Emirates

Armstrong Building Products L.L.C.

P.O. Box 73831

Phone: +971 43 397 099

Fax: +971 43 397 088

www.armstrong.eu